



**Judgebook
ESPL - ESQJ
2026**

European Mobile Media Association

www.emmanet.com

Welcome to the European Mobile Media Association

Preface.....	2
6.0 ESPL judging manual.....	2
6.0.1 How to correctly classify a car	2
TRUNK:	3
Wall category	6
X-category	7
6.0.2 What is a stripper pole	7
6.1 Installation.....	8
Presentation to the public	8
Cleanliness	8
Main Fuse present y/n	9
Are all wires to the components fused	9
Fuse of appropriate value	9
Interior wires invisible	12
All components securely mounted	13
Does the vehicle allow a normal use.	13
Visibility	15
First Optic impression	15
Overall design of car	16
6.2 Measurement	16
6.2.1 How to place the sensor in the car.	16
6.2.2 SPL Sensor Stand.	17
The winners	17
8.0 ESQJ judging manual.....	18
8.0.1 Class and Categories	18
8.2 Installation.....	18
Presentation to the public	18
Cleanliness	19
Main Fuse present y/n	19
Are all wires to the components fused	19
Fuse of appropriate value	20
Interior wires invisible	22
All components securely mounted	23
Does the vehicle allow a normal use?	23
Visibility	25
First Optic impression	26
8.3 SQ Judging	27
Judge Tonal Accuracy by using track 11	27
Tonal accuracy (0 - 120 points)	27
Overall spectral balance	30
Listening pleasure	30
Bonus for enjoyment to public	31
8.1.3 Position of SQ judge	32
General Rule to be aware of:.....	32
The winners	33

Welcome to the European Mobile Media Association

Preface

This manual is designed to describe the exact procedure, used for judging the ESPL and ESQJ of a vehicles audio system, according to EMMA Rules and regulations and will be continuously updated. In all price limited ESPL classes only unmodified components are allowed. On request of the judge the competitor must give a proof that regular retail material is in use. In case of cheating an immediate disqualification will follow.

6.0 ESPL judging manual

6.0.1 How to correctly classify a car

Competitors are always grouped together so that they are all on an equal playing field and should be able to challenge one another for the victories.

Firstly, to be allowed to compete in Trunk, B/R or Wall categories the car must meet these requirements:

T, B/R and W

- The audio system can be installed by anyone.
- The car must be registered with a license number.
- The car must have driver and passenger side seats (with back) made for automotive use and to be used for driving the car. The car must be able to be driven on its own by a driver sitting in the car.
- The car must have OEM driver and passenger side doors that must be able to be opened for the dedicated measurement. It is not allowed to block or make the door opening smaller than it is as OEM. Modified door panels are allowed.
- Doors can be closed using only original locking mechanisms.
- In money limited classes no supercaps and no battery packs made combining lower voltage cells (LTO, LifePO4 single cells or similar) are allowed.
- No obstructions except OEM components between the two door openings.
- No "room in room" builds allowed. No sealed structures inside the windshield and front side windows allowed.
- Only original windshield and windows thickness is allowed.
- The maximum voltage is 14,6 Volts with the engine running, or not, measured on the amplifier's power input.
- No modified or self-built active (=power supplied) equipment is allowed (e.g. head unit, line driver, amplifier, active crossover etc.).
- A maximum of two channels of amplification are allowed per physical installed woofer (two channels bridged to one is counted as one)
- All components of the audio-system have to be installed into the car – trailers etc. are not allowed.

Then we check if they can meet the requirements for the Trunk category.



TRUNK:

- The subwoofers (including enclosures, ports, etc.) must be installed in the trunk area, with a maximum height no higher than the top of the original rear seat, not headrests. When the headrests are fixed to the backseat then you need common sense and count them as headrests and not as the backseat.
- The rear seats must be lockable or fixable in OEM upright position (90 degrees or more). During the measurements the rear seats can be folded down.
- The rear seats must be usable as seats in a way as intended by the factory. Original seat height, original back rest angle, etc. No batteries etc. in the footroom or in front of the backseat.
- The car must be approximate to the “original” from C-pillar to the front.
- Panel modifications (door, kick, dash, etc.) are allowed from C-pillar to front.
- The cars can be damped, but all original interior panels must fit. Otherwise they will be promoted to the category where the installed type of damping is allowed
- The source unit must be installed and fixed properly into the car.
- Sealing the trunk opening, door openings or covering any windows with hard materials (wood, metal etc.) is not allowed.

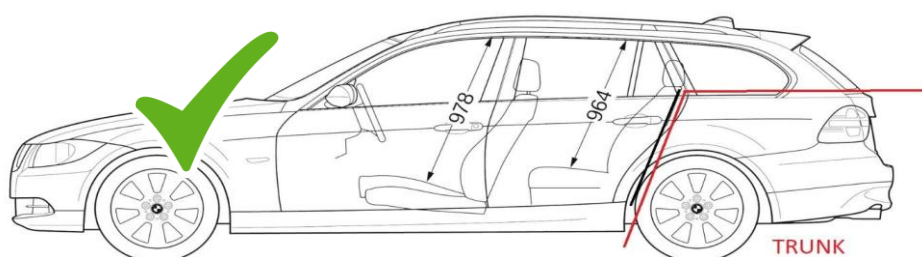

When checking to see if the enclosure is in the trunk you must use a line parallel to the ground, the example below although exaggerated is wrong.

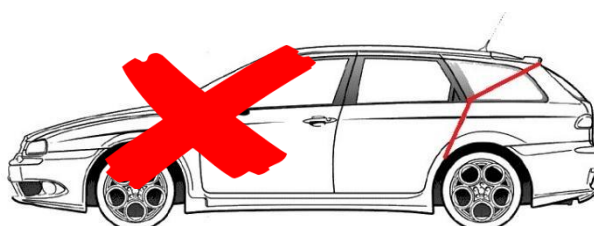

Once we know if the competitor can meet the installation requirements for Trunk category we then split this down into the two possible classes as per the value of the audio system. Price limit includes DSP, subwoofer amplifiers, woofers and any additional batteries. Additional batteries must be added to the car's value sheet in the EMMA Value Database. Batteries are valued by their capacity and battery technology.

- ESPL Trunk 3000 €
- ESPL Trunk Limited

If the competitor cannot meet the criteria for the Trunk category then we look at B/R-category.

B / R classes

B / R classes are grouped together as the size of the woofer enclosures would be comparable for the same car.

Common rules for B/R-classes

- The car must be approximate to the “original” from B-pillar to the front.
- Panel modifications (door, kick, dash, etc.) are allowed from B-pillar to front. The cars can be damped from B-pillar to front, but original interior panels must fit. Otherwise they will be promoted to the category where the installed type of damping is allowed. It can be heavily damped from B pillar to the back.
- A Roof-Brace (“stripper pole”, max d=10cm) is allowed
- The source unit can be installed properly into the car or out of the car.
- During the measurements the backseats can be down or up, this is the decision of the competitor.
- Sealing the trunk opening, door openings or covering any windows with hard materials is not allowed.

Differences between B and R installations, rules for B:

- B means that the subwoofers, enclosure and port must be behind the (front) of the B-pillar and no higher than the original backseats without headrests.
- There is no specific point for measuring, just follow the line of the B-pillar.
- If the B-pillar has a curve, simply follow the curve as your measurement point.

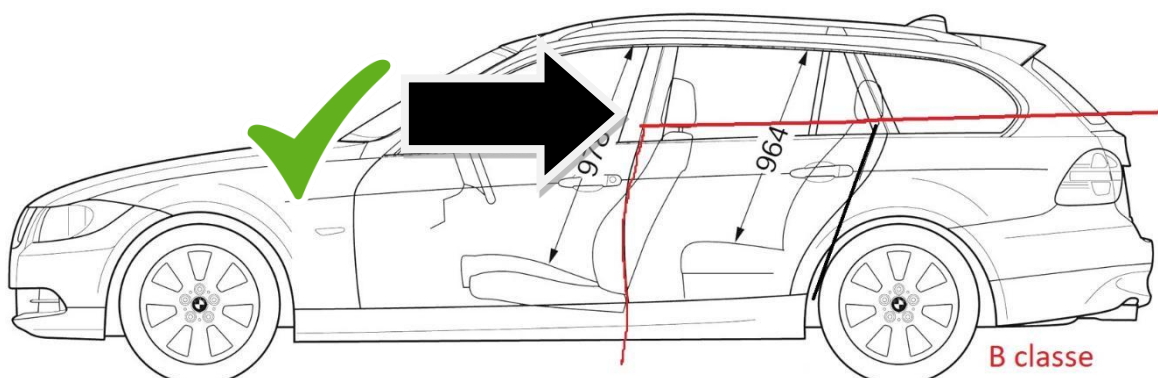

In the sketch the backseat is very high, just to give you an impression. As long as the backseat is original. When checking to see if the enclosure is valid for B / R Unlimited you must use a line parallel to the ground as shown above, the two examples below although they are exaggerated are both wrong.

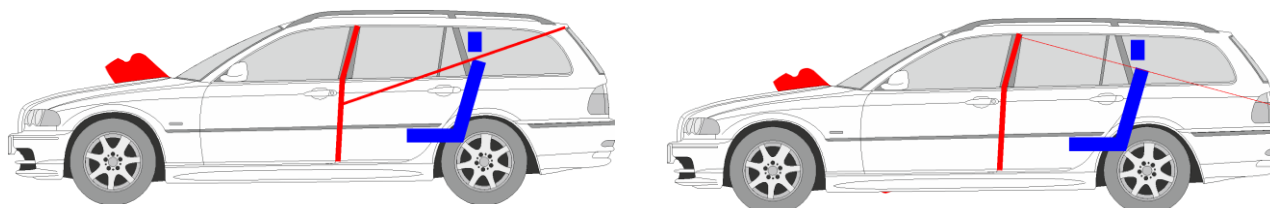

Differences between B and R installations, rules for R:

- R means that the subwoofer, enclosure and port must be installed behind the back seats and can be installed up to the roof.
- The rear seat needs to be in the OEM locked position. If the OEM position has more one locked angle, then the competitor is free to use any position.
- From the top most point of the rear seat, the enclosure should form a vertical line and should NOT encroach onto the passenger cabin space.

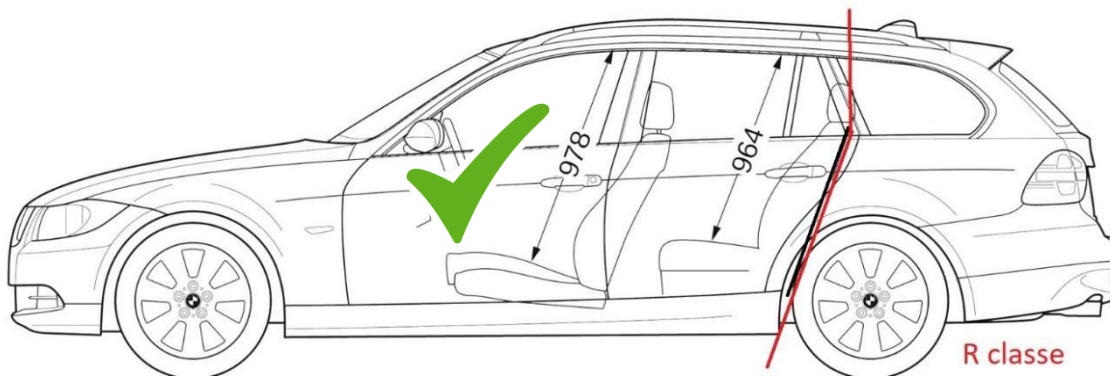

The diagram below shows a car that would not be allowed in R as the enclosure encroaches on the passenger cabin.

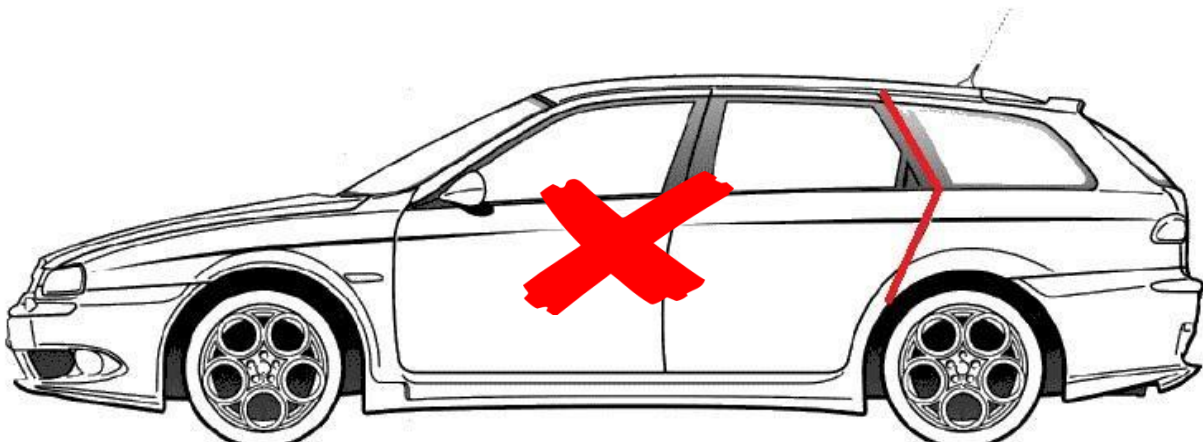

Once we know if the competitor can meet the installation requirements for B/R-category we then split this down into the two possible classes as per the value of the audio system. Price limit includes DSP, subwoofer amplifiers, woofers and any additional batteries. Additional batteries must be added to the car's value sheet in the EMMA Value Database. Batteries are valued by their capacity and battery technology.

- ESPL B/R 4000 €
- ESPL B/R Limited

If a car cannot fit in B/R-category we then check to see if it meets the criteria for W-category or it will be placed in Expert.

Wall category

- W (Wall) means that the subwoofers, enclosure and port must be installed behind the front of the B-pillar and can be up to the roof.
- There is no specific point for measuring, just follow the line of the B-pillar.
- If the B-pillar has a curve, simply follow the curve as your measurement point.
- All sound producing equipment incl. Power Supply can be installed everywhere, as long as it does not affect the normal use of the car.
- The car must be approximate to the “original” from B-pillar to the front.
- Panel modification (door, kick, dash, etc.) are allowed from B-pillar to front.
- The cars can be damped from B-pillar to front, but original interior panels must fit except the roof liner. Otherwise they will be promoted to the category where the installed type of damping is allowed
- Besides that, it can be heavily damped from B pillar to the back
- Roof-Brace (“stripper pole”, max d=10cm) is allowed
- The source unit can be installed properly into the car or out of the car.

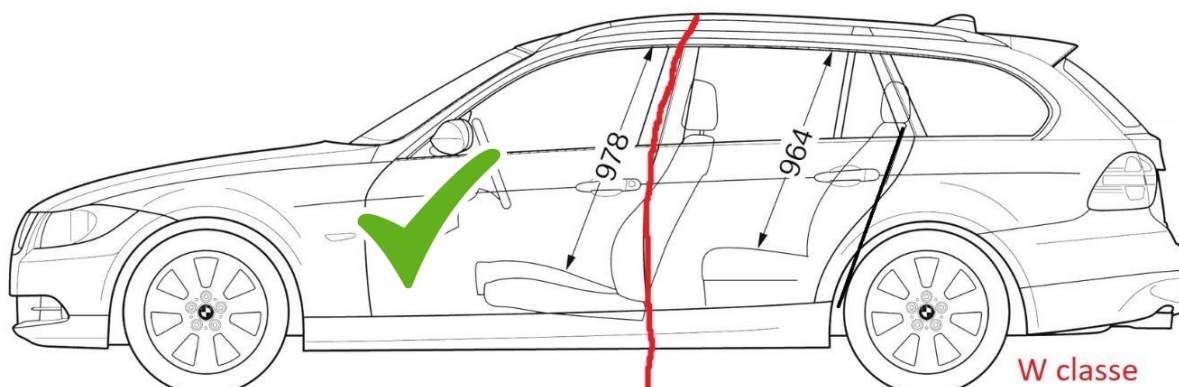

The diagram below shows a car that would not be allowed in W as they have not followed the line of the B pillar

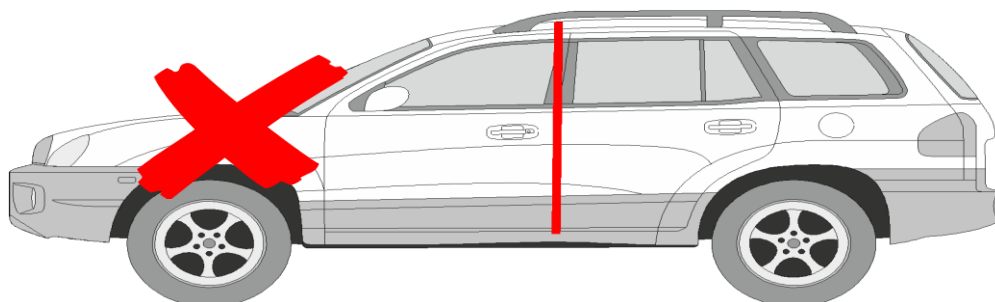

Once we know if the competitor can meet the installation requirements for W-category we then split this down into the two possible classes as per the value of the audio system. Price limit includes DSP, subwoofer amplifiers, woofers and any additional batteries. Additional batteries must be added to the car's value sheet in the EMMA Value Database. Batteries are valued by their capacity and battery technology.

- ESPL W 8000 €
- ESPL W Limited

If a car cannot fit in W-category it will be placed in X-category.

X-category

- No restrictions, the car does not have to be officially registered
- The car must have a driver seat with back made for automotive use and to be used for driving the car.
- The car must be able to drive on its own by a driver sitting in the car
- The car must have driver and passenger side door approximating the OEM that must be able to be opened for the dedicated measurement.
- Doors can be closed using only OEM locking mechanisms
- No obstructions except OEM components and roof brace ("stripper pole", max d=10cm) between the two door openings
- No "room in room" builds allowed. No sealed structures inside the windshield and front side windows allowed
- In ESPL X competitors are allowed to build bracing on the inside of the windshield and side windows. The biggest allowed size is 4cm around the window measured from the part limiting the OEM view. The size of the bracing must be measurable during judging or documented by photo log. 4cm is measured on the glass.
- All components of the audio-system have to be installed into the car – trailers etc. are not allowed.

6.0.2 What is a stripper pole

All classes except Trunk are allowed the use of a stripper pole. A stripper pole is a pole (with a max diameter of 10cm) which can be used in order to reduce the flexing of the car body by bracing between the floor and the roof. This pole should not be connected to the enclosure as per the example below. If a vehicle has a strut brace larger than 10cm or it is fitted to the enclosure, it must be removed by the competitor.

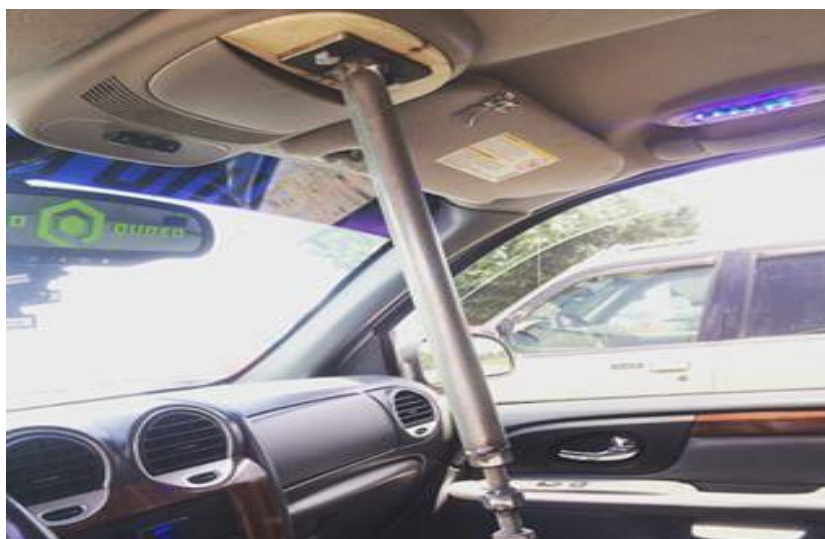

6.1 Installation

Once the Competitor is assigned to the correct class, the install judging can take place. The installation judging procedure follows the standard EMMA installation judging process in accordance with the matrix below.

Matrix ESPL		
	T/ R / B / W	Expert
	110+	114+
Measurement with open doors		
Measurement with closed doors		
Presentation to the public	10	10
Cleanliness	6	6
Main fuse(s) present y/n	10	10
Are all wires to the components fused?	15	15
Is the fuse value appropriate to the wire size?	20	20
Any interior wires visible?	5	5
Are all components securely mounted?	24	24
System/Wiring diagram	4	4
Does the vehicle allow a normal use?	6	
Visibility	(-6) / 0	
First Optic impression	10	10
Overall design of vehicle		10

Presentation to the public

The competitor should:

- 'Show off' their vehicle & installation to the public during the event time/s.
- Allow spectators to listen to the system.
- Please note: This will be checked several times a day
- If it is an outdoor event and the weather is poor, the car can be closed but system details should still be visible. (E.g. displayed on the dashboard etc.)
- Exception: at the event active judges / back-office staff's cars can remain closed due to safety reasons.

Points will be deducted as appropriate, i.e. commensurate to the time the car is not being shown to the public.

Cleanliness

Cars should be clean and presentable, the Car exterior should be "car-wash-clean" and interior should be vacuumed (not perfect but reasonably clean). The criteria you should check against are as follows:

- Car Wash clean y/n
- Passenger compartment clean y/n
- Dedicated components (e.g. Batteries or fuse holders etc) of the system installed in the engine component and trunk clean y/n

- No items i.e.: clothing, tools, and food wrappers on display?

Deduct 2 points per not cleaned area, Minimum 0 Points

Main Fuse present y/n

Check if a 'Main Fuse' has been installed onto the (or each) main power wire within 40cm from any positive battery post and/or before passing any metal panel. This should include all wires from the battery post.

Any permanent wires installed into the car for battery charging even if they are not in use shall also be judged for fusing.

NOTE: If more than one battery is installed, each battery needs a main fuse from its battery post. If batteries are joined to each other within 40cm of each battery post, it will be considered as one big battery. At this point the fuse rating is not checked.

If any main fuse is not present, 0 points will be awarded

Are all wires to the components fused

Check, if a fuse is installed on the positive power wire for every component belonging to the audio/multi-media system.

All fuses connected to the components must be visible within three minutes (for all fuses in total, not three minutes for every fuse!!!). The judge should check to ensure the following components are fused:

- Head Unit
- Other devices
- Amplifiers

Deduct 2 points per component that is NOT fused or whose fuse is not visible within the 3 minutes. Minimum 0 Points

NOTE: The fuse rating is not checked at this point.

System/Wiring Diagram

A Power diagram is necessary for judging.

EMMA Back Office will hand out a form at the registration where all components, wire diameters as well as fuses should be filled in by the competitor in case that no wiring diagram is prepared and available for the judging process.

2 Points for each diagram if present

Fuse of appropriate value

Check every fuse that belongs to the audio system is of an appropriate size for the wire it is protecting (according to the VW75212 - Dimensionierung von Leitungen und Sicherungen im Kraftfahrzeug):
When checking the fuse rating this should be appropriate for the smallest size cable in the circuit used to power the component, Positive or Negative, according to the table below:

NOTE: Fuse rating is based on mm² the AWG sizes are just for reference.

Fuse Size Matrix			
	Cable size	AWG	Fuse Rating
	0,5mm ²	20	10 Ampere
	1,0mm ²	17	15 Ampere
	1,5mm ²	15	20 Ampere
	2,5mm ²	13	20 Ampere
	4,0mm ²	11	30 Ampere
	6,0mm ²	9	50 Ampere
	10mm ²	7	60 Ampere
	16mm ²	5	100 Ampere
	25mm ²	4	125 Ampere
	35mm ²	2	175 Ampere
	50mm ²	0	250 Ampere
	70mm ²	2/0	300 Ampere

Alternatively, wire sizes and fuse ratings can be calculated with the formulas in the “**How to calculate wire sizes**” section below. If the competitor chooses to use a fuse rating for a cable not shown in the standard table above, the calculations must be documented and provided to the judges for checking.

NOTE: All of these fuses should be visible within three minutes, not three minutes per fuse.

Deduct 2 points per incorrect or NOT fused component, minimum 0 Points

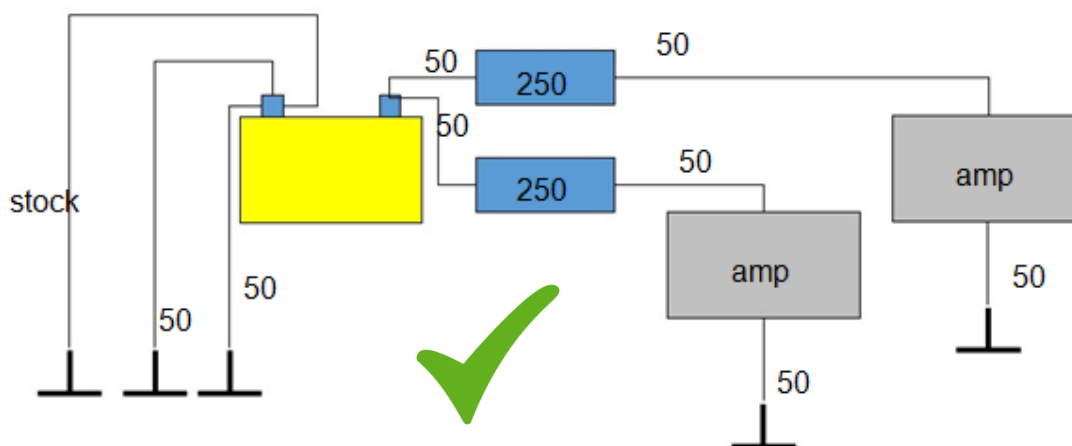

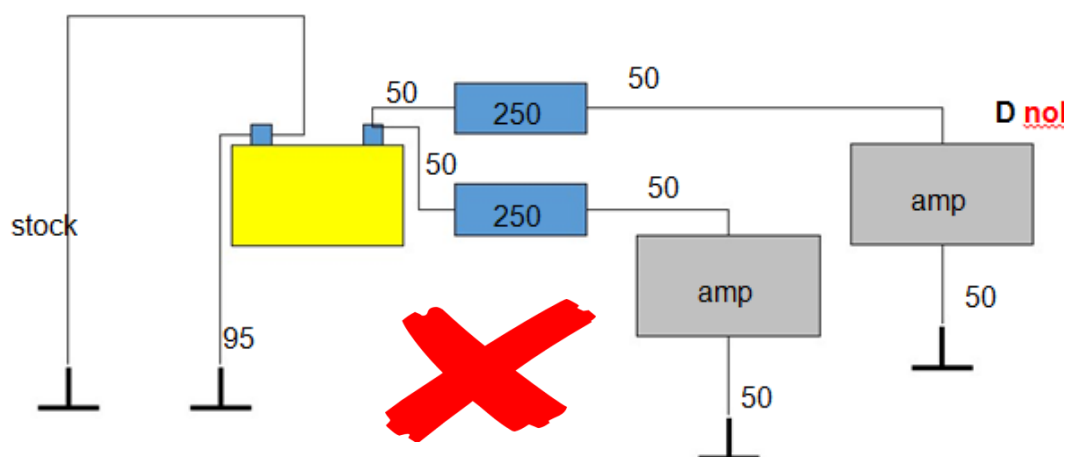
**NOTE FOR COMPETITORS:****How to calculate wire sizes**

How to check, if the wire size is appropriate (e.g. IF the OEM ground cable is not upgraded):

Calculate wire size:

$$A = (I \times 0,0175 \times L \times 2) / (fk \times U)$$

A= wire size in sqmm

I = max amperage

0,0175 specific resistance of OFC copper in Ohm x mm² / m (for CCAW the factor must be 0,0283)

L = cable length (of entire circuit including positive & ground wire) in m

fk = factor of loss, E.g.: 2%, is 0,02

U = voltage (for T, B/R and W categories use U = 12 V, for X-category use the nominal voltage of the system)

Factor of loss should be no higher than 2%

If the calculated wire size is not available, step up to next available wire size

Important info:

In case CCAW-cable is used, there must be 1,6x more sqmm or it can handle 0,625x the current of OFC-cable. It is assumed that the OEM-ground wire is OFC.

Competitor/installer needs to calculate the appropriate wire sizes for his installation and document it to the judges.

If the calculation is not available for the judges, the published table for wire sizes and fuse values will be used for judging

Formula changed to I to determine capability of a given ofc cable:

$$I = (A \times fk \times U) / (0,0175 \times L \times 2)$$

Guidance for cars equipped with Intelligent Battery Sensor (IBS) / Smart Charge Alternator / Stop Start Technology.

When a vehicle has a sensor on the OEM Chassis ground wire to the battery, all current must pass through the sensor to maintain a fully functioning Intelligent Battery System. E.g. "Stop/start" technology.

It is up to the competitor to design and install the audio system to the current rulebook.

EMMA is aware of two ways to maintain the function of the (IBS) sensor and comply with the rulebook, (there may be more):

1. Fuse the main power cable for the audio system to the maximum value the OEM Ground wire would allow (using the calculations above).
2. Add an extra (appropriate size) ground wire from the IBS sensor to the chassis or audio system.
3. If the car's OEM ground cable is not upgraded the biggest allowed size for the main fuse (or combined size of multiple main fuses) is 100 A unless the competitor provides a calculation with the enclosed formula using car's OEM ground cable size.

If in doubt, please consult your vehicle manufacturer for further advice.

Interior wires invisible

Check if any wires of the audio system installation are visible. This is judged from 'the drivers seating position'. This should be done with the doors closed.

- Any cables behind the B pillars are not judged.
- Cables under the dash should not be judged unless these are visible whilst sitting on the drivers' seat.

NOTE: Mobile devices such as smartphones that are connected by a cable to a connector on the HU/Car AND the device itself will be operated at the head unit, the mobile device is treated as a storage device and no attention will be given to this cable.

If the mobile device is used to operate the system (e.g. to change the track would be enough), there should be no wire visible (however the connector being visible is ok)!

Hint: This could also mean that the device must be fixed / installed - because it streams...

Deduct 2 points for any visible system wire, Minimum 0 Points



All components securely mounted

Check all components by physical inspection to ensure they are fixed. Each component (shown below) should be checked to ensure they are secure. The security of the component should be proportionate with its size and weight. An 18" sub will need more securing than a tweeter would.

The judges should look for:

- Head Unit
- Other devices
- Amplifiers
- Speakers

NOTE: If any of the above items are not installed then no deduction will take place.

Deduct 2 points per not fixed component, minimum 0 Points

Does the vehicle allow a normal use.

EMMA is allowing modifications to the vehicle's interior (except in OEM) to install audio components. The driver/ passenger should be able to sit comfortably and be able to operate the controls of the car without obstruction (look for sub/speakers up front or too high raised floor).

As the OEM designers have given the most safety and comfort in the limited available space of the passenger cabin, EMMA will use the OEM surfaces as references.

The passenger foot room must not be smaller than the OEM foot room on the driver side between seat and pedals.

Judging will be done in the regular driving position of the vehicle's operator.

The Judge should check that the space deemed necessary, to correctly operate the car, by the manufacturer has not been encroached upon and that this same amount of space is available for the front seat passenger.

When checking this space the two front seats should be parallel so as to ensure the same space is available. To ensure the same space is available you should check the height width and depth as illustrated below.



There are three things to check for height.

1. The height from the floor to the top of the seat
2. The height from the floor to the top of the uppermost pedal
3. An unrestricted line should be able to be drawn between both of vertical lines.

Note: If the floor of the passenger side has been raised (to a MAX of 4 CM) then these heights need to be maintained.

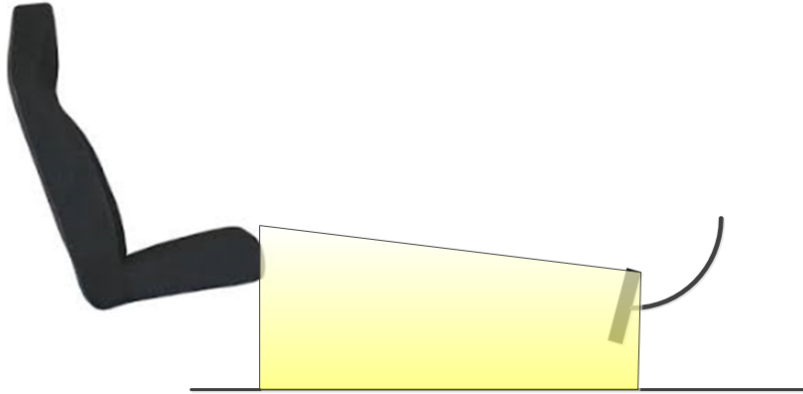

When checking the width you should ensure the following:

- Width from left most to right most peddle is maintained.
- When checking the left and right most peddle these should include all of the following (if fitted)
 - Accelerator
 - Brake
 - Clutch
- The width of the seat is maintained
- An unrestricted line should be able to be drawn between both of width lines as below.

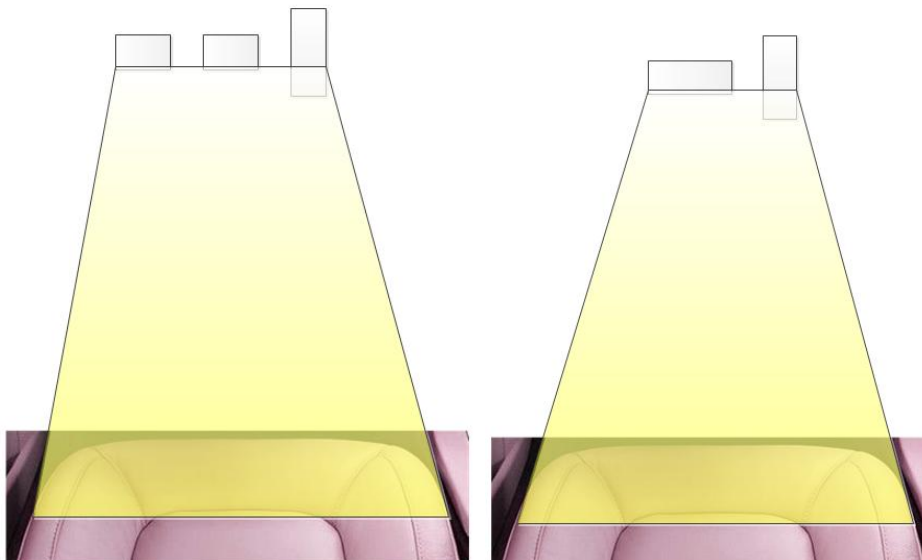

Note: The width at the pedals could move one way or the other but this width must be maintained and a straight line from the side of the seat to each side of the foot well needs to be maintained.

Deduct 2 points per element that is restricting the OEM standards. Maximum -6 Points

Visibility

The judge will sit in the designated listening position and check if anything from the Audio systems Installation is interfering with the view. This rule applies to the windscreen and the two front side windows. Triangular windows within the A-Pillar/ front doors will not be considered as long as the view through these windows is not higher and/or longer than half the height and length of the side window.

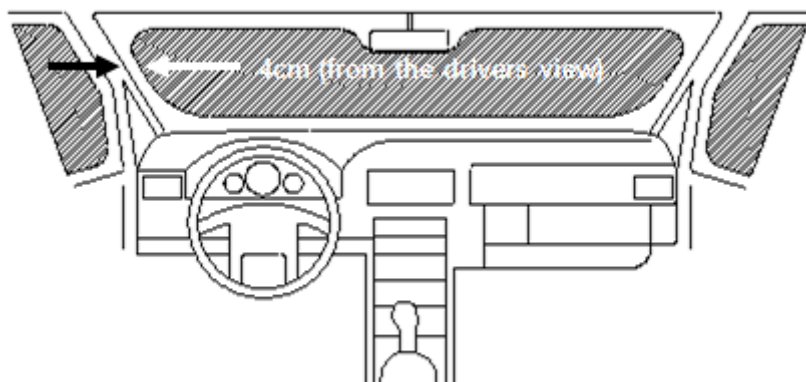

If the view is restricted, the Judges deduct 3 Points for each not OK Situation.

- the view to the side mirrors should not be blocked (if no passenger side mirror installed, the rear view mirror must allow a full view back)

How to Judge

The measurement will be taken as follows:

- 4 cm perpendicular height taken 90 degrees to the road surface, when checking from the bottom of the screen or the side windows.
- When measuring on the windscreen the measurements are always taken from the edge of any opaque areas which are part of the screen. IE the LAST, smallest black dot
- 4 cm from the A-pillars at 90 degrees to the A-pillar.

Hint:

- This does not include the actual screen used for media playback.
- If the audio build is greater than the 4 cm measurement but is still NOT obscuring the road, (e.g. it is obscuring only the car bonnet), then this is acceptable.

How to score (deduction):

3 points will be deducted per build that obscures the view to a maximum of 6 points.

First Optic impression

Check all components to ensure they create the impression of "a finished installation" and not an "under construction" impression. You will need to look at the following items:

- Head Unit
- Other devices
- Amplifiers
- Speakers / Speaker enclosures
- Cover and trim panels.

Deduct 1 point per "under construction" component, Minimum 0 Points

Overall design of car

To score full points, the car itself and the components installed in it must show a design theme that was followed throughout the car; inside, outside and to the trunk compartment. It should be immediately clear that the car was designed as a project from beginning to end, with a clear statement to the judges and the viewers.

The kind of design theme is of no matter; but the competitor should be aware that an original looking car will not be able to score any points on the areas where no effort for design was taken.

Deduct 1 point per element not following the design idea, Minimum 0 Points

6.2 Measurement

For all ESPL, ESQJ Tuning Classes the actual, designated Music Material is to be used. Additional signals are not allowed during the official measurements. The Term Lab Software will recognize the infeed of additional signals. By using additional signal the competitor will be disqualified from the competition.

The competitor is allowed to start the track wherever he wants to, for example he wants to start at 1.32 from the start of the track chosen for your competition day this is allowed.

The competitor himself needs to prove it is the normal driving position.

It's not allowed to skip front or back in the track during the measurement, once you start to play the track you should allow it to play uninterrupted.

All the competitors will be playing the same track during the competition.

6.2.1 How to place the sensor in the car.

The Sensor Mount, as shown in section 6.2.2, should be placed on the driver's seat base pushed as far back as possible. This is to emulate as closely as possible the position of the driver's head.

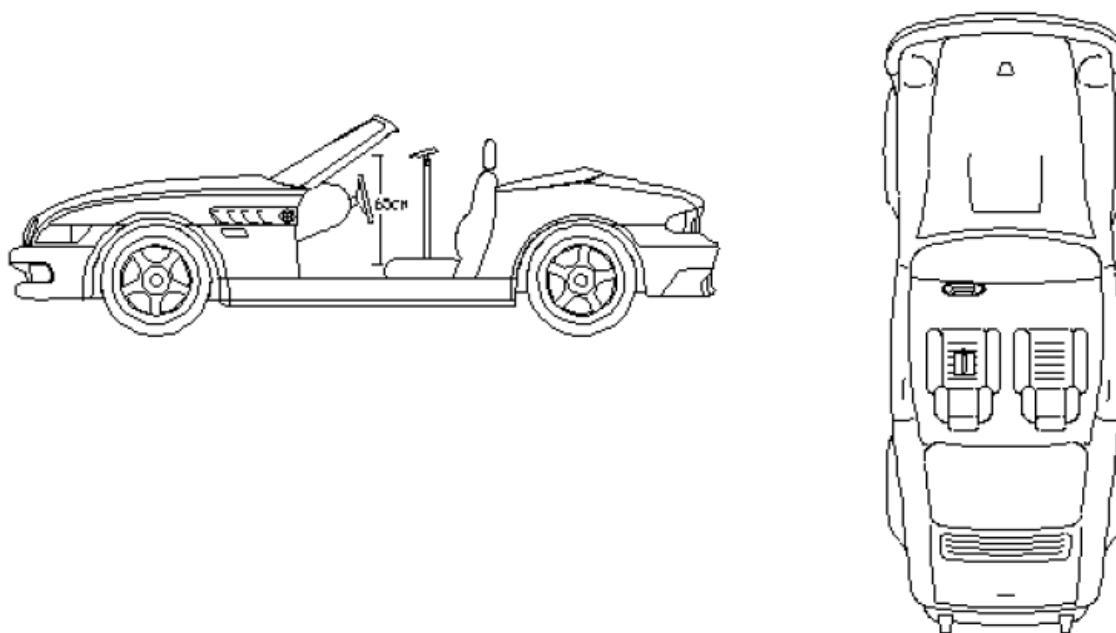

With the sensor in place, two measurements will be taken as follows:

- Measurement with the doors open will be measured as the average of 30 sec.
- Measurement with the door closed will be measured as the average of 30 sec.

If the competition takes place outdoors, the engine can be running during the measuring but must not exceed 2000 RPM.

6.2.2 SPL Sensor Stand.



The winners

The Competitor with the highest total points wins. In case of a tie, it will be decided in order by:

- Total SPL score WINS. If still a tie
- Highest Score of Open door measurement WINS.
- If still a tie higher Install scoring wins

D.



8.0 ESQL judging manual

The ESQL competition format was formed by EMMA Philippines and EMMA Thailand to open a competition arena for those who enjoy listening to good sound quality outside their cars.

Installation judging is also required but with less degree than ESPL and of course a sound quality judging outside the car. The Sound Quality judging contains Tonal Accuracy and Spectral Balance according to the EMMA SQ requirements. In addition, the Listening Pleasure will also be judged but with a track chosen by the competitor.

8.0.1 Class and Categories

1. ESQL Limited
2. ESQL Unlimited

The rules for classification are identical to ESPL, described in the official EMMA Rulebook. On a National level or with the agreement of EMMA headquarters the ESQL Categories can be divided and extended along the lines of the ESPL Categories and Classes.

8.2 Installation

The Competitor will show the judge their installation of the Car Media system. The judge will score as per the normal installation process, covering the install sections below, and will explain immediately the scores to the competitor.

Matrix ESQL	L	U
Install Total	110	104
Presentation to the public	10	10
Cleanliness	6	6
Main fuse(s) present y/n	10	10
Are all wires to the components fused?	15	15
Is the fuse value appropriate to the wire size?	20	20
Any interior wires visible?	5	5
System/Wiring Diagram	4	4
Are all components securely mounted?	24	24
Does the vehicle allow a normal use?	6	
Visibility	(-6) / 0	
First Optic impression	10	10

Presentation to the public

The competitor should:

- 'Show off' their vehicle & installation to the public during the event time/s.
- Allow spectators to listen to the system.
- Please note: This will be checked several times a day

- If it is an outdoor event and the weather is poor, the car can be closed but system details should still be visible. (E.g. displayed on the dashboard etc.)
- Exception: at the event active judges / back office staff's cars can remain closed due to safety reasons.

Points will be deducted as appropriate, i.e. commensurate to the time the car is not being shown to the public.

Cleanliness

Cars should be clean and presentable, the Car exterior should be "car-wash-clean" and interior should be vacuumed (not perfect but reasonably clean). The criteria you should check against are as follows:

- Car Wash clean y/n
- Passenger compartment clean y/n
- Dedicated components (e.g. Batteries or fuse holders etc) of the system installed in the engine component and trunk clean y/n
- No items i.e.: clothing, tools, and food wrappers on display?

Deduct 2 points per not cleaned area, Minimum 0 Points

Main Fuse present y/n

Check if a 'Main Fuse' has been installed onto the (or each) main power wire within 40cm from any positive battery post and/or before passing any metal panel. This should include all wires from the battery post.

Any permanent wires installed into the car for battery charging even if they are not in use shall also be judged for fusing.

NOTE: If more than one battery is installed, each battery needs a main fuse from its battery post. If batteries are joined to each other within 40cm of each battery post, it will be considered as one big battery. At this point the fuse rating is not checked.

If any main fuse is not present, 0 points will be awarded

Are all wires to the components fused

Check, if a fuse is installed on the positive power wire for every component belonging to the audio/multi-media system.

All fuses connected to the components must be visible within three minutes (for all fuses in total, not three minutes for every fuse!!!). The judge should check to ensure the following components are fused:

- Head Unit
- Other devices
- Amplifiers

Deduct 2 points per component that is NOT fused or whose fuse is not visible within the 3 minutes. Minimum 0 Points

NOTE: The fuse rating is not checked at this point.

System/Wiring Diagram

A Power diagram is necessary for judging.

EMMA Back Office will hand out a form at the registration where all components, wire diameters as well as fuses should be filled in by the competitor in case that no wiring diagram is prepared and available for the judging process.

2 Points for each diagram if present

Fuse of appropriate value

Check every fuse that belongs to the audio system is of an appropriate size for the wire it is protecting (according to the VW75212 - Dimensionierung von Leitungen und Sicherungen im Kraftfahrzeug):

When checking the fuse rating this should be appropriate for the smallest size cable in the circuit used to power the component, Positive or Negative, according to the table below:

NOTE: Fuse rating is based on mm² the AWG sizes are just for reference.

Fuse Size Matrix			
	Cable size	AWG	Fuse Rating
	0,5mm ²	20	10 Ampere
	1,0mm ²	17	15 Ampere
	1,5mm ²	15	20 Ampere
	2,5mm ²	13	20 Ampere
	4,0mm ²	11	30 Ampere
	6,0mm ²	9	50 Ampere
	10mm ²	7	60 Ampere
	16mm ²	5	100 Ampere
	25mm ²	4	125 Ampere
	35mm ²	2	175 Ampere
	50mm ²	0	250 Ampere
	70mm ²	2/0	300 Ampere

Alternatively, wire sizes and fuse ratings can be calculated with the formulas in the “**How to calculate wire sizes**” section below. If the competitor chooses to use a fuse rating for a cable not shown in the standard table above, the calculations must be documented and provided to the judges for checking.

NOTE: All of these fuses should be visible within three minutes, not three minutes per fuse.

Deduct 2 points per incorrect or NOT fused component, minimum 0 Points

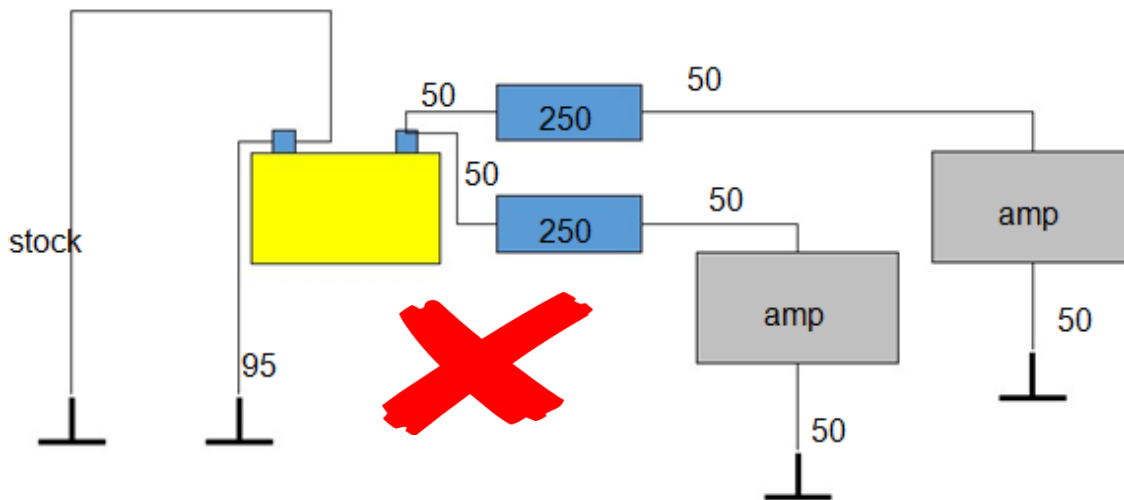
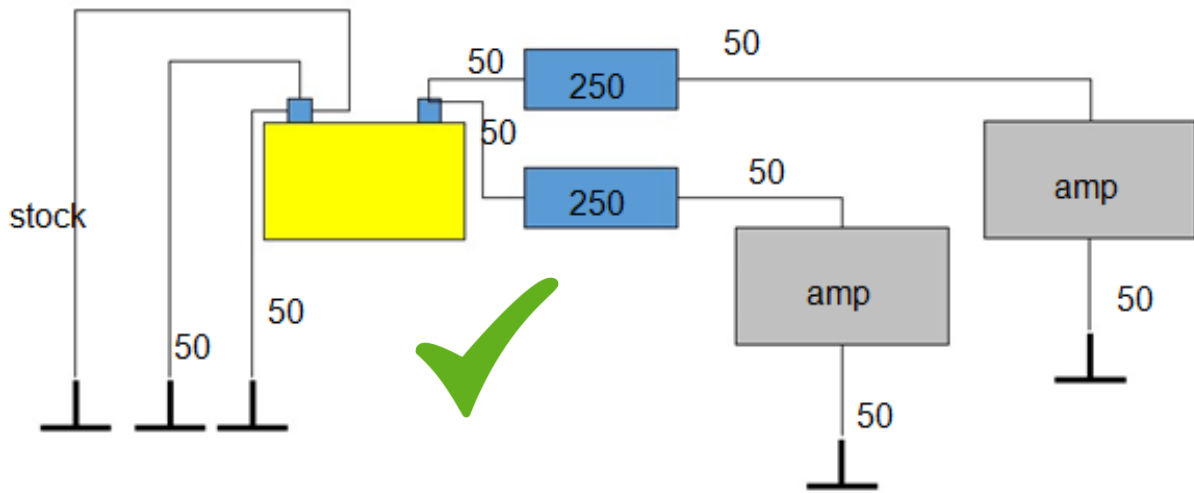
**NOTE FOR COMPETITORS:****How to calculate wire sizes**

How to check, if the wire size is appropriate (e.g. IF the OEM ground cable is not upgraded):

Calculate wire size:

$$A = (I \times 0,0175 \times L \times 2) / (fk \times U)$$

A= wire size in sqmm

I = max amperage

0,0175 specific resistance of OFC copper in Ohm x mm² / m (for CCAW the factor must be 0,0283)

L = cable length (of entire circuit including positive & ground wire) in m

fk = factor of loss, E.g.: 2%, is 0,02

U = voltage

Factor of loss should be no higher than 2%

If the calculated wire size is not available, step up to next available wire size

Important info:

In case CCAW-cable is used, there must be 1,6x more sqmm or it can handle 0,625x the current of OFC-cable. It is assumed that the OEM-ground wire is OFC.

Competitor/installer needs to calculate the appropriate wire sizes for his installation and document it to the judges.

If the calculation is not available for the judges, the published table for wire sizes and fuse values will be used for judging

Formula changed to I do determine capability of a given ofc cable:

$$I = (A \times f_k \times U) / (0,0175 \times L \times 2)$$

Guidance for cars equipped with Intelligent Battery Sensor (IBS) / Smart Charge Alternator / Stop Start Technology.

When a vehicle has a sensor on the OEM Chassis ground wire to the battery, all current must pass through the sensor to maintain a fully functioning Intelligent Battery System. E.g. "Stop/start" technology.

It is up to the competitor to design and install the audio system to the current rulebook.

EMMA is aware of two ways to maintain the function of the (IBS) sensor and comply with the rulebook, (there may be more):

1. Fuse the main power cable for the audio system to the maximum value the OEM Ground wire would allow (using the calculations above).
2. Add an extra (appropriate size) ground wire from the IBS sensor to the chassis or audio system.
3. If the car's OEM ground cable is not upgraded the biggest allowed size for the main fuse (or combined size of multiple main fuses) is 100 A unless the competitor provides a calculation with the enclosed formula using car's OEM ground cable size.

If in doubt, please consult your vehicle manufacturer for further advice.

Interior wires invisible

Check if any wires of the audio system installation are visible. This is judged from 'the drivers seating position'. This should be done with the doors closed.

- Any cables behind the B pillars are not judged.
- Cables under the dash should not be judged unless these are visible whilst sitting on the drivers' seat.

NOTE: Mobile devices such as smartphones that are connected by a cable to a connector on the HU/Car AND the device itself will be operated at the head unit, the mobile device is treated as a storage device and no attention will be given to this cable.

If the mobile device is used to operate the system (e.g. to change the track would be enough), there should be no wire visible (however the connector being visible is ok)!

Hint: This could also mean that the device does not need be fixed / installed - because it streams...

Deduct 2 points for any visible system wire, Minimum 0 Points



All components securely mounted

Check all components by physical inspection to ensure they are fixed. Each component (shown below) should be checked to ensure they are secure. The security of the component should be proportionate with its size and weight. An 18" sub will need more securing than a tweeter would.

The judges should look for:

- Head Unit
- Other devices
- Amplifiers
- Speakers

NOTE: If any of the above items are not installed then no deduction will take place.

Deduct 2 points per not fixed component, minimum 0 Points

Does the vehicle allow a normal use?

EMMA is allowing modifications to the vehicles interior (except in OEM) to install audio components.

The driver/ passenger should be able to sit comfortably and be able to operate the controls of the car without obstruction (look for sub/speakers up front or too high raised floor).

As the OEM designers have given the most safety and comfort in the limited available space of the passenger cabin, EMMA will use the OEM surfaces as references.



The passenger foot room must not be smaller than the OEM foot room on the driver side between seat and pedals.

Judging will be done in the regular driving position of the vehicles operator.

The Judge should check that the space deemed necessary, to correctly operate the car, by the manufacturer has not been encroached upon and that this same amount of space is available for the front seat passenger.

When checking this space the two front seats should be parallel so as to ensure the same space is available. To ensure the same space is available you should check the height width and depth as illustrated below.



There are three things to check for height.

1. The height from the floor to the top of the seat
2. The height from the floor to the top of the uppermost pedal
3. An unrestricted line should be able to be drawn between both of vertical lines.

Note: If the floor of the passenger side has been raised (to a MAX of 4 CM) then these heights need to be maintained.

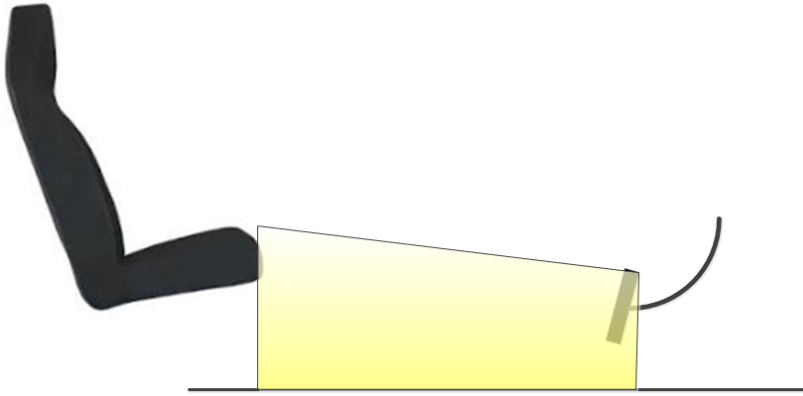

When checking the width you should ensure the following:

- Width from left most to right most peddle is maintained.
- When checking the left and right most peddle these should include all of the following (if fitted)
 - Accelerator
 - Brake
 - Clutch
- The width of the seat is maintained
- An unrestricted line should be able to be drawn between both of width lines as below.

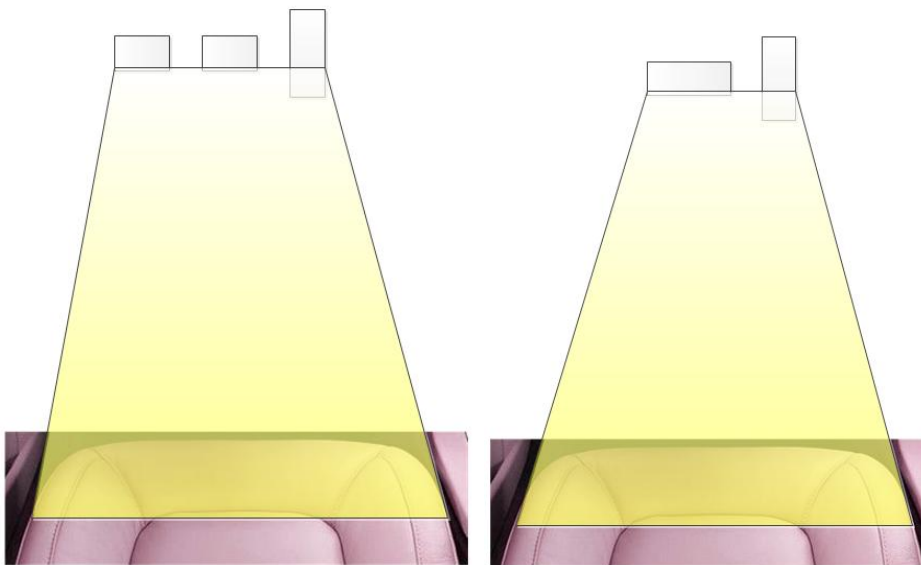

Note: The width at the pedals could move one way or the other but this width must be maintained and a straight line from the side of the seat to each side of the foot well needs to be maintained.

Deduct 2 points per element that is restricting the OEM standards Maximum -6 Points

Visibility

The judge will sit in the designated listening position and check if anything of the Audio systems Installation is interfering the view. This rule applies to the wind shield and the two front side windows. Triangular windows within the A-Pillar/ front doors will not be considered as long as the view through these windows is not higher and/or longer than half the height and length of the side window.

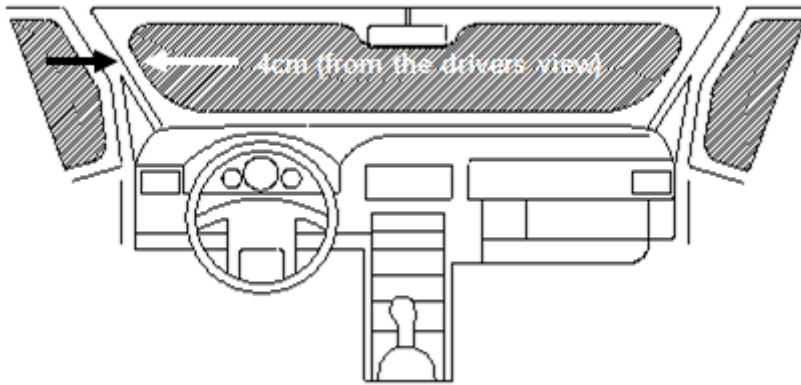

If the view/use is restricted, the Judges deduct 3 Points for each not OK Situation.

- the view to the side mirrors should not be blocked (if no passenger side mirror installed, the rear view mirror must allow a full view back)

How to Judge

The measurement will be taken as follows:

- 4 cm perpendicular height takes as 90 degrees to the road surface, when checking from the bottom of the screen or the side windows.
- When measuring on the screen the measurements are always taken from the edge of any opaque areas which are part of the screen. IE the LAST, smallest black dot
- 4 cm from the A-pillars at 90 degrees to the 4 pillar.

Hint:

- This does not include the actual screen used for media playback.
- If the build is greater than the 4 cm measurement but is still NOT obscuring the road, only the car bonnet, then this is acceptable

How to score (deduction):

3 points will be deducted per build that obscures the view to a maximum of 6 points.

First Optic impression

Check all components to ensure they create the impression of "a finished installation" and not an "under construction" impression. You will need to look at the following items:

- Head Unit
- Other devices
- Amplifiers
- Speakers / Speaker enclosures
- Cover and trim panels.

Deduct 1 point per "under construction" component, Minimum 0 Points



8.3 SQ Judging

The judge will score as per the normal SQ judging process, covering the SQ sections below. This will however NOT be done from the driver's seat. In ESQL the position of the judges is set as per section 8.3.1.

Matrix ESQL		L	U
	Sub-Bass	30	30
	Mid-Bass	30	30
	Midrange	30	30
	High Freq.	30	30
	Overall spectral balance	30	30
	Listening pleasure	30	30
	Bonus for enjoyment to public	6	6

Judge Tonal Accuracy by using Track No. 16, Should have done it like this

Every instrument & voice should sound very natural & distinct, without affecting the sound of another. Detailed Information about the titles is written in the SQ Judgebook

The track for tonal accuracy contains the following instruments and Vocals:

male & female voices, Drums, tambourine, cowbell, handclaps, different electric guitars, acoustic guitar, electric bass, Hammond organ, trumpets, tenor sax, alto sax, trombone

The song has a steady rhythmic foundation with dynamic bass, allowing listeners to evaluate low-frequency performance and kick-drum impact.

The track opens with the deep singer's voice soon joined by electric guitars and the female voice. As additional synth layers and percussion are introduced, the mix becomes denser, which helps reveal how well an audio system maintains instrument separation and detail without sounding compressed or muddy. High-quality systems should reproduce these layers clearly while preserving the balance between bass, midrange, and treble.

The vocal performance remains central throughout the song. This makes the track effective for judging midrange accuracy and vocal presence, as the lead vocalist should sound natural, well-defined, and stable within the stereo image. During the chorus sections (2:03), the arrangement expands with brighter synths and stronger dynamics, offering a good test for soundstage width and high-frequency clarity. From 2:23 the trumpet (left center) and guitar solo (right center) should stay clearly separate from the other instruments.

Because the song maintains high energy while introducing subtle changes in arrangement and intensity, it allows listeners to evaluate how well a system handles dynamic range and transient response.

Tonal accuracy (0 - 120 points)

Use the following scoring guide to score Sub-Bass, Mid-Bass, Midrange, Highs, & Overall Spectral Balance.

- A 29 to 30 points. 98% to 99%** Joyful, amazing, wonderful, shuddering, unbelievable tuneful, substantial, sexy, full of emotion
 Life Like - Completely Natural & Clear, generate full feelings, emotions, shuddering, warm, inviting, relaxing sound, Voices/instruments breath, with space around them, 99% Harmonically & Musical,
 All details are there, All Instrument tones are 100% Distinct & Separate, The s,x,f,c sound perfect,
 The hardware disappears; nothing comes between you & the music, completely effortless sound
 Full of endless Energy & Dynamics, all tones start & stop with great precision & energy. Perfect Instrument Size, Real Vocals in full body with flesh and blood
- B 27 to 28 points. 95% to 97%** it feels extremely close to, but just a little bit less than the above
 Very Close to Completely Natural & Clear, Generate almost full feeling, shuddering, extremely close to the above, Almost 99% Harmony & Musicality
 Almost all details are there, All Instrument tones are almost 100% Distinct & Separate, The s,x,f,c sound almost perfect
 The hardware almost disappears, Almost Effortless,
 Almost full of Energy & Dynamics, almost all tones start & stop with great precision & energy.
 Very close to Perfect Instrument size, Real vocals with almost full body
- C 24 to 26 points. 90% to 94%** Everything is there in very good proportion, but just not good enough
 A great deal of Naturalness & Clarity, generate a lot of feelings, no shuddering, a lot of space & atmosphere, but not enough, a great deal of Harmony & Musicality.
 Most of the details are there, Most tones are very Distinct & Separate, The s,x,f,c sounds a little bit thicker or thinner than normal,
 Wide open window to the sound, the hardware adds tiny coloration, little effort in a few tones,
 A great deal of Energy & Dynamics, most tones starts & stop with great precision & energy,
 A little smaller or bigger Instrument size, Close to real vocals with close to full body
- D 21 to 23 points. 85% to 89%.** Almost everything is there in good proportion, but something is obviously missing, or is too much.
 Fair Naturalness & Clarity, generate fair feelings, Space is medium or little larger than normal,
 Fair Harmony & / or Musicality
 A few details are missing, Most tones are almost very Distinct & Separate, The s,x,f,c sound thicker or thinner than normal
 Almost open window to the sound, the hardware adds little color, Little Effort in a lot of tones.
 Fair Energy & Dynamics, some tones start & stop with great precision & energy
 Fairly smaller or bigger instrument size, Close to real vocals with little less body.
- E 18 to 20 points. 80% to 84%** Sounds correct, but there are missing things or does not give much music feeling
 Little Naturalness & Clarity, Generate little feelings, little space & atmosphere, little Harmony & / or Musicality,

A few details are there, a lot of tones are very Distinct & Separate, the s, x,f,c sound a lot thicker or thinner than normal.

A couple of tones behind a curtain, colorations more obvious, Fair Effort in a few tones, Little Energy & / or Dynamics, only a couple of tones start & stop with great precision & energy.

A few Instruments smaller or bigger size, good vocals with half size body.

- F 15 to 17 points. 75% to 79%** Sounds nice but some tracks sound nicer than others.
 Only some tones Natural & / or Clear, Generate feeling only in a few tones, Space & atmosphere only in some notes & / or instruments, Harmony & / or M in a few tones
 Details only in few tones, a lot of tones are almost very Distinct & Separate, the s,x,f,c sound a little blur or whistling.
 Some tones behind a curtain, colorations obvious, Fair Effort in a lot of tones
 Energy & / or Dynamics in only a few tones, Acceptable transients.
 A lot of Instruments smaller or bigger size, good vocals with very small or very big body.
- G 12 to 14 points. 70% to 74%** Sounds acceptable, nothing annoying but not so clear.
 Not Natural but clean, generate feeling only in little tones, too much space, Harmony & / or M musicality in little tones,
 Very little details, A few tones are Distinct & / or Separate, the s,x,f,c sound blur or whistling.
 A lot of tones behind a curtain, many colorations, a lot of effort in a few tones
 Energy & / or Dynamics only in a couple of tones, acceptable transients only in a specific range.
 Quite smaller or bigger Instrument size, Acceptable vocals with no body.
- H 9 to 11 points. 50% to 69%** Sounds acceptable, almost nothing annoying
 Not Natural but almost clean, no Feelings, no Space, or enormous Space, Almost No Harmony & / or Musicality
 Almost no details, Little tones are Distinct & / or Separate, The s,x,f,c sound blur or whistling a lot.
 The curtain is obvious, A lot of effort in a lot of tones,
 Almost no Energy & / or Dynamics, Poor transients.
 Half or Double size Instruments, almost acceptable vocals with no body.
- I 5 to 8 points. 30% to 49%** Sounds annoying in only some tones or tunes
 Not Natural, some tones clean, some opposite feelings, Space & Atmosphere not easy to detect,
 No Harmony & / or Musicality
 Hard to detect details, Almost no Distinction & / or Separation, the s,x,f,c sound harsh,
 The curtain is heavy, big effort in a few tones,
 No Energy or Dynamics, very poor transients,
 Very big differences in instrument size, poor vocals with no or enormous body
- K 1 to 4 points. 1% to 29%** Sounds annoying in almost all tunes and tracks
 Not Natural, bad feelings, Space not detectable, No Harmony & / or Musicality
 No details, no distinction & separation, Hard to listen to,
 The curtain is very thick & heavy, big effort in a lot of tones,
 No Energy & Dynamics, No transients,
 Cannot detect instrument size, cannot detect vocal size.

Additional hints:

Mistakes or miss-adjustments in the crossover area should result to lower score on both e.g. Midrange and High Frequency sections.

Never score 0 if there is a sound and avoid going lower than (5 to 8) unless it is absolutely necessary.

Overall spectral balance

Here we judge all the above (Sub, Mid-Bass, Midrange, & Highs) as a whole - as one thing. How all the frequencies - the entire bandwidth - are blended/combined. How is the sound as a total? Are they well linked together, or not?

Track 16 of the actual EMMA Competition tracks

Well balanced track. All instruments should sound clear and rich. The position of every single instrument is spot on.

Overall Spectral Balance (0 - 30 points)

Additional hints:

Although it appears so, Overall Spectral Balance is not a point average, given to Sub-bass, Mid-Bass, Midrange & High frequencies

Small point differences between Sub-bass, Mid-Bass, Midrange & Highs, gives a point result in Overall SB that looks like a point average of the above.

Big point differences between Sub-bass, Mid-Bass, Midrange & High frequencies can give a lot lower points in Overall Spectral Balance

Overall Spectral Balance scoring can never be higher than the highest point in Tonal Accuracy

Overall Spectral Balance scoring can be lower than the lowest point in Tonal Accuracy

Never score 0 if there is a sound and avoid going lower than (5 to 8) unless it is necessary.

Listening pleasure

Listening pleasure will be judged by using Competitor's own choice of Track (Song)

During Listening pleasure the competitor is allowed to adjust the volume.

It's the pleasure and joy that music can generate to the listeners.

Considering all musical tracks, score the following:

Naturalness	0 to 3 points
Harmony &Musicality	0 to 3 points
Atmosphere & Emotions	0 to 3 points
Clarity	0 to 3 points
Effortless sound	0 to 3 points
Dynamics & Energy	0 to 3 points
Distinction & Separation	0 to 3 points
Body of Voice & Instruments	0 to 3 points
Transparency	0 to 3 points
Details	0 to 3 points

How to score:

- 0 points for no Naturalness at all
- 1 points for little Naturalness
- 2 points for fair Naturalness
- 3 points for perfect Naturalness

Hints:

The scoring here seems to have a connection with the Overall Spectral Balance scoring. These 2 scorings are not directly connected, but the actual scorings cannot be far away from OSB under normal circumstances.

You must score listening pleasure from a different point of view.

Do you get pleasure from the music you are listening to? Or you do not?

Under most cases listening pleasure will score proportional to Overall Spectral Balance points at higher level. E.g. SB=20 points LP=18 to 20 points

It can be that a system not so good in SB gives some listening pleasure & can score proportionally a little higher. E.g. SB=18 points, LP=20 to 22 points

It is not realistic to score 18 on the Overall Spectral Balance and score 25 on listening pleasure.

It is not realistic to score 28 on the Overall Spectral Balance and score 12 on listening pleasure.

A sound system that sounds very good or excellent, should be able to show it throughout the whole score sheet.

On a sound system that does not sound so good, you have to point this out in detail throughout the score sheet.

Never score 0 and avoid scoring below 5 unless it is absolutely necessary.

Even a bad (not a very bad) sounding car should score around 10 points.

Bonus for enjoyment to public

The Competitor is allowed to choose any music track, but this musical track must be in good taste. It must not be lewd or have suggestive lyrics. The Competitor can provide a performance to the crowd whilst this extra track is being played if they so wish. The length of the extra track/performance is limited to 5 minutes unless otherwise announced prior to the start of the judging process.

During the extra track the competitor will receive scores for Listening pleasure and also for public enjoyment up to a total of 6 points.

These 3 aspects are just examples because any presentation can be unique.

- Max of 2 points for originality.
- Max of 2 points for effects and coordination.
- Max of 2 points for overall effort.



8.1.3 Position of SQ judge

The Sound Quality Judge(s) should stand between 5 and 15 meters from the car, the exact distance is the decision of the competitor. If the competitor does not advise the judges to keep a defined distance the distance will automatically be 5 meters. The position of the car is decided by the competitor and does not necessarily need to be behind the car.

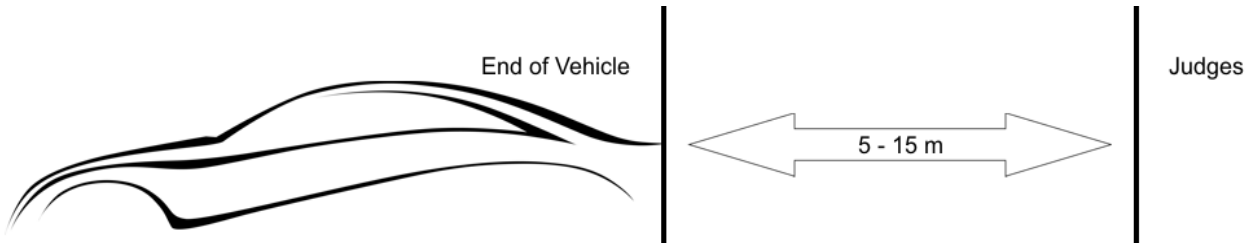

General Rule to be aware of:

1. Only the owner of the car or competitor can operate the volume control
2. The judges will not adjust any volume control, track selection control and head unit power switch.
3. Other than the bonus track, Only the official EMMA ESPL judging CD is to be used for the judging process and the announced track will be played
4. The maximum voltage is 14.6 Volts with engine running.
5. A maximum of two (2) physical amplifier-channels for each physically installed woofer is allowed, except in Unlimited Class
6. Cars with modified active equipment must compete in Unlimited Class
7. In some EMMA ESPL (ESQL) categories, it is requested that subwoofers including enclosures, ports, etc. must be installed in the trunk area (rear seat can't be taken out).
8. A front system must be installed and play audible music during measurement, if the front system is not audible there will be a 10-point deduction. It should be installed according to the official EMMA Rulebook. If the front system is installed in another or even dangerous way the car must compete in Unlimited
9. The competitor is responsible for his/her equipment and EMMA takes over no responsibility or guarantees in case of any damage to the sound system or the vehicle.
10. It is the competitor's decision if he/she sits inside the car during the judging process. EMMA is not responsible for damages to the health of the competitor but strongly recommends being careful!!!
11. The vehicle must be shown to the public after the judging procedure is finished. The organizers will point out an area for presentation. In that case the cars must be presented to the public. If the presentation does not happen the judge or Event Director will take back the 10 points from presentation to the public.
12. Only officially registered cars are allowed to compete, and they must be able to be driven inside and outside the judging area by using their own engine.
13. No additional power supplies are allowed to be connected to the mains during the judging procedure process => no external power supply

14. All competitor cars must have driver and passenger side seats installed in original condition or similar (sport seats, etc.).
15. All components of the audio-system must be installed into the vehicle – trailers etc. are not allowed
16. During the measurement only the person that would operate the volume is allowed inside the car. No one should block the two front doors during this time.
17. Additional batteries are allowed to be installed and must be properly mounted and fused.
18. The source unit must be installed properly into the car or mounting rack outside the car is accepted.
19. If during measurement the head unit stops/blocks/jumps, the system or a component of the system fails/breaks down, etc. the competitor has a second chance to start over after 2 minutes. The same if he used accidentally another
20. Only the official designated EMMA ESPL tracks will be used for measuring SPL
21. A Passive membrane is not counted as speaker.

The winners

Competitor with the highest total points win. In case of a tie, will be decided in order by

- E. Total of Tonal and Spectral balance WINS. If still a tie
- F. The competitor with highest Tonal score WINS. If still a tie
- G. The competitor with highest Listening Pleasure WINS.

If competitors still tied and a new track would be given, and a re-judge will take place of these cars.

EMMA is poered by:

AI·SONIC

accuton®
by Thiel & Partner

Art in Motion

Audiocircle

AudioControl®
Making Good Sound Great™

audison

GERMAN CAR AUDIO
3RAX



CONFUSE
AUDIO

COMFORT
SOUND DEADENING

CD
AUDIO

CS CAR AUDIO
SuperNaturalSound

Dragster
AUDIO ART

EX CAR MEDIA SYSTEMS

FOCAL®

FOR-X

FOUR

GAS
AUDIO POWER

GOLDHORN
Your listening experience is our priority.

GERMAN
MAESTRO

GLADEN®
GERMAN TECHNOLOGY

GROUND ZERO®
GERMAN ENGINEERING

HELIX
GERMAN CAR HIFI

HERTZ

HIFONICS
POWER FROM THE GODS

JL AUDIO®
Ahead of the Curve®

KICKER
PERFORMANCE AUDIO

MATCH
BY AUDIOTEC FISHER

morel

MOSCONI
GLADEN AUDIO EUROPE

MUSWAY
MUSIC IS THE WAY

PHOENIX GOLD

Pioneer

PARAMAT
SOUND DEADENING MANUFACTURES

QUARTORIGO

Rebec
CAR AUDIO

REISS AUDIO

RS
Audio

SILENT®
OAT

SounDigital

Stinger

STP STANDARTPLAST

VENOM®

VIBE
BRITISH AUDIO

V⁺ibrofiltr